



E-9000

# ULTRA-LOW HUMIDITY STORAGE CABINETS 1, 3%RH



Prevent your components from micro-cracking during reflow with proper Ultra-Low Humidity Storage.

Micro-crack

## Features

**Conforms to IPC/JEDEC J-STD-033B Standard for Handling, Packing, Shipping and Use of Moisture/Reflow Sensitive Surface Mount Devices.**

**Conforms to IEC-61340-5-1 (ESD) Standard for Handling**

- Dehumidifies ICs to prevent micro-cracking and can be used as an alternative to baking
- DXU Model cabinets can maintain 1%RH
- Powerful moisture absorbent is utilized to eliminate the use of nitrogen
- No maintenance is required as moisture absorbent is automatically refreshed
- Cabinets are grounded to prevent static electricity
- Wide range of cabinet sizes available

Manufacturer  ERC Co., Ltd.

# Why do components require low humidity storage?

## McDry™ Prevents Micro-Cracking of IC Packages During Reflow.

The high temperatures involved in vapor phase or reflow passes cause the absorbed moisture to expand rapidly. Micro-cracking occurs in nearly 100% of IC packages containing moisture during the reflow process. Occurring over an extended period of time, this can cause breakage of wiring and other problems. Micro-cracking can be prevented with storage and dehumidification of IC's using McDry™ as well as resetting the floor life of components according to the IPC/JEDEC J-Std 033b.

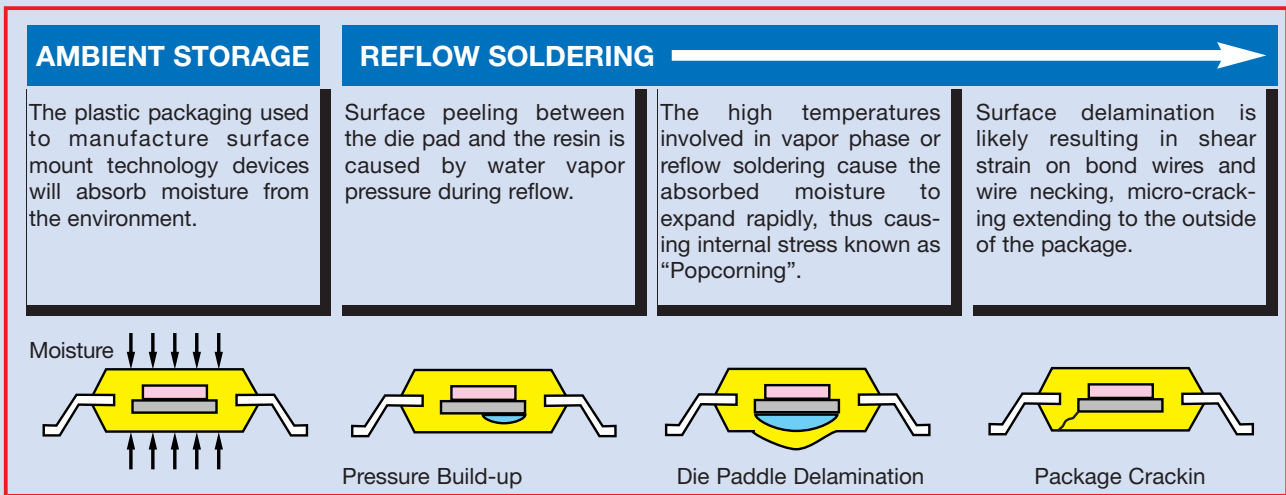
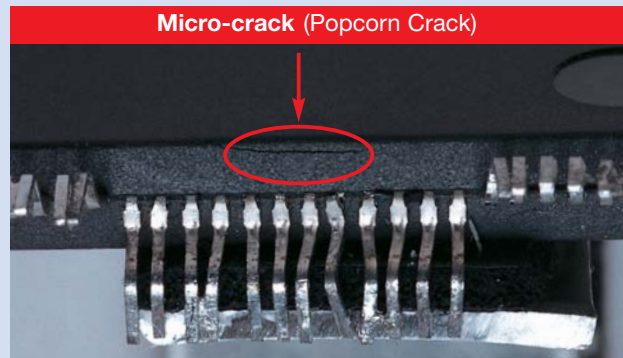



## McDry Applications

- 1** Low humidity storage of IC packages (MSD) which have been removed from moisture barrier bags. (To stop the floor life clock of CSPs, BGAs, TQFPs, etc.)

  - 1) Low humidity storage of MSDs before and leftover after implementation.
  - 2) Low humidity storage of MSDs that have been removed from mounter.
  - 3) Low humidity storage of MSDs when writing ROMs.
- 2** Drying and storing multilayer PC boards before and after mounting.



- 3** Dry storage of pattern film and prepreg used in the manufacturing of PCBs.

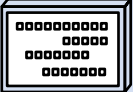

- 4** Dry storage of semi-mounted PCBs. Effective low humidity storage of PCBs awaiting second-side reflow.

- 5** Clean, room temperature drying of liquid crystal glass boards after washing. Results in even drying and prevents contamination.

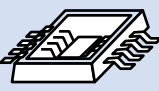

- 6** Dry storage of quartz crystals and electrode adhesives used in the manufacturing of quartz oscillators.

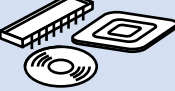
- 7** Drying and storing of fiber optics (Micro-lens for WDM) and CCD (Solid-state image sensor.)

- 8** Low humidity storage of electronic components to slow down oxidation.

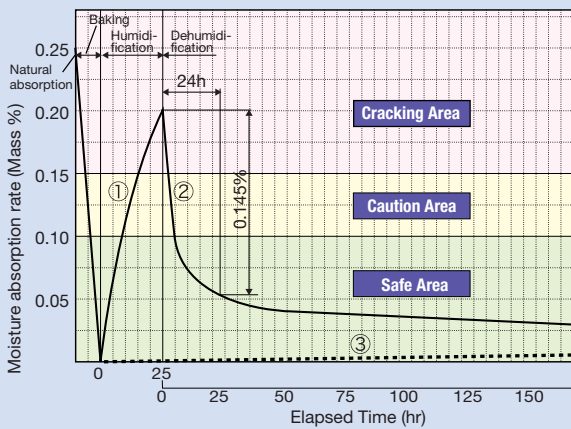

# Absorption and Dehumidification Data of IC Packages



## PBGA

Test Sample: PBGA  
 Pretreatment: Baked at 125 °C, 24 hrs.

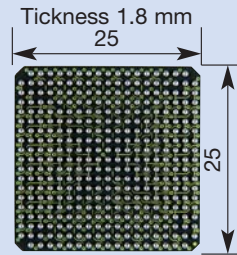

## Conditions

1. Package is stored in simulated room conditions (30°C, 85% RH, 24 hours). A controlled temperature, humidity chamber is used.
2. After Process 1 above has been completed, the package is stored in a low humidity storage case for 100 hrs at 5% RH.
3. After the baking process the package is stored in a low humidity storage case at 5% RH.

# Low Humidity Storage of Thin Multi-Layer PCBs

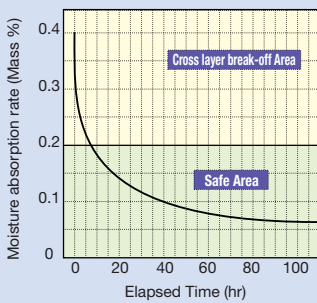

Multi-layered PCBs absorb moisture at a faster rate as they become thinner. Layer break off and blistering will occur during reflow if the moisture content of the PCB exceeds 0.2% (weight).

Test Sample: 6 layer Glass Epoxy PCB  
 Size: 50 x 100 x 1t (mm)  
 Pre-Treatment: Baked for 24 hours @125°C  
 Humidification: Steamed for 2 hours  
 De-Humidification: Stored in McDry™ Cabinet @5%RH

# Opening-Closing Data of DXU-1001

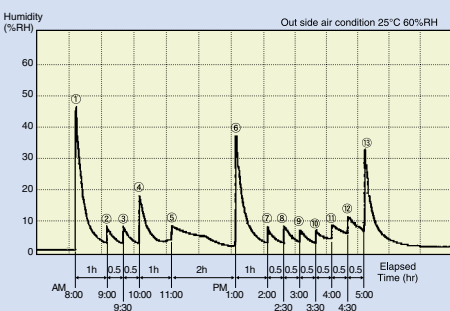

## The door opening place and time

- No. ①...4doors (A)(B)(C)(D) ...2 min. open all
- No. ②⑤⑦⑨⑩⑪⑫...1door (A) ...20 sec. open
- No. ③⑧...1door (A) ...30 sec. open
- No. ④...2doors (A)(B) ...30 sec. both open
- No. ⑥...2doors (A)(B) ...2 min. both open
- No. ⑬...2doors (A)(B) ...1 min. both open

# Humidity Data of McDry Cabinets

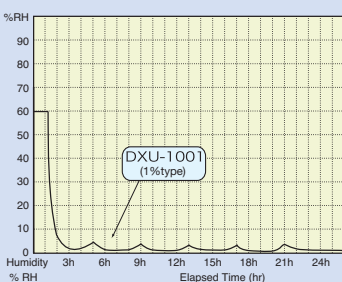

Test Conditions:  
 25°C  
 60% RH

**DXU-1001 (1% RH Model):**  
 Internal RH

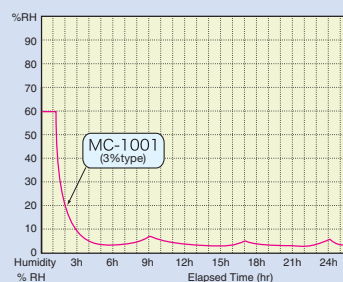

Test Conditions:  
 25°C  
 60% RH

**MC-1001 (3% Model):**  
 Internal RH

## Manufactured for High Performance



- Locking doors that seal tightly
- Solid steel construction with ESD safe design
- Adjustable shelves (stainless steel available)
- Digital RH meter



Range  
Humidity: 1~90%RH  
Accuracy:  $\pm 3\%$ RH

- Drying Unit
- Features
  1. Powerful zeolite desiccant eliminates the need for nitrogen.
  2. Desiccant is automatically recycled and does not require replacement.



Cabinet is grounded to prevent component damage due to static electricity.

- ESD safe casters
- Standard for 501,1001,1002 sized cabinets.

## Dehumidifying Principle

### Dehumidifying Principle

McDry™ Electronic Drying Storage Cases provide low humidity storage without the use of nitrogen. Humidity is removed from the cabinets by use of a powerful zeolite desiccant. The desiccant is automatically recycled with a heating mechanism and does not require replacement. Moisture absorbed by the zeolite desiccant is vaporized and released outside of the cabinet. Memory shaped metal is utilized for fail proof ventilation. Forced air-flow convection system desiccates the entire cabinet without requiring the use of a fan for optimal dehumidification to take place.

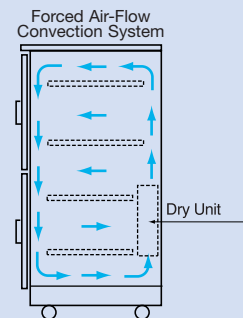
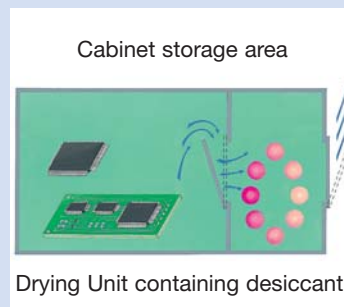

## Handling and Storage Guidelines of IC Packages

### Storing in 5% RH and 10% RH storage cabinets in accordance with IPC/JEDEC J-STD 033B

In accordance with IPC/JEDEC J-STD-033B, IC packages that have been removed from MBBs must be kept under a condition of 5% or 10% relative humidity to prevent components from absorbing moisture. However, during the mounting process, opening and closing of dry cabinet storage doors may occur frequently in order to remove and replace moisture-sensitive devices. This will allow ambient air

to flow into the cabinet and may raise the RH level. To limit this from occurring and to keep the relative humidity inside of the cabinet below 5% or 10% as specified, a consistent, ultra-low humidity storage level is recommended. Therefore, the storage guidelines utilizing the McDry™ cabinet corresponding to the repetition of opening and closing of doors are as follows:

Model	RH level	Frequency of opening-closing of doors	Usage example
DXU models	1% RH	Once in approx. 20 – 40 mins.	<ol style="list-style-type: none"> <li>1. Ultra-low humidity storage of IC's for cabinets that are accessed frequently.</li> <li>2. Storage of IC packages that require ultra-low humidity storage such as components with high MSL classifications.</li> </ol>
MCU models	3% RH	Once in approx. 1 hr – 2 hrs.	<ol style="list-style-type: none"> <li>1. Ultra-low humidity storage of IC's for cabinets that are not accessed frequently.</li> <li>2. Long-term storage of IC packages and electrical components.</li> <li>3. Storage of PCBs, etc.</li> </ol>

## DXU Model 1%RH

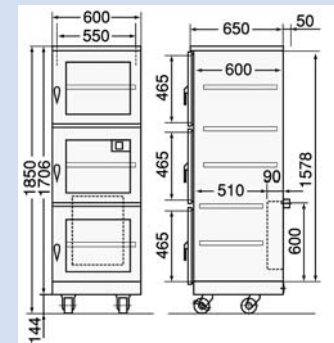
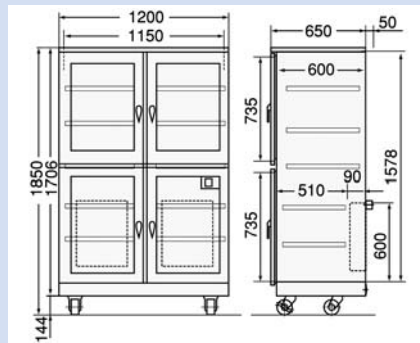
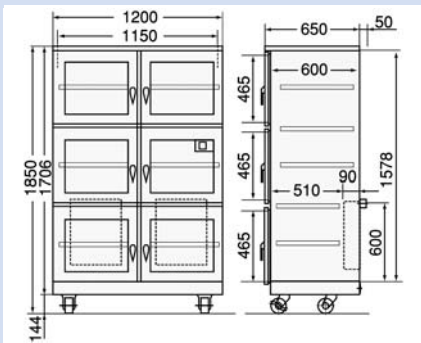

**Specifications:** (Note: Specifications are subject to change due to product improvement.)

Item/Model	DXU-1001	DXU-1002	DXU-501
External Dimensions (mm)	1200 W x 700 D x 1850 H		600 W x 700 D x 1850 H
Internal Dimensions (mm)	1150 W x 600 D x 1610 H		550 W x 600 D x 1610 H
Capacity	Approx 1200 L		Approx 600 L
Dry Unit	US-5000 x 2		US-5000 x 1
Material	Bonderized steel with melamine coating		Bonderized steel with glass windows
Color	Silver		
Door (Magnetic)	6 Doors with glass windows	4 Doors with glass windows	3 Doors with glass windows
Weight	Approx 200 Kg	Approx 190 Kg	Approx 110 Kg
Electrical Requirement	230 V 94 W/h (Max 740 W)		230 V 47 W/h (Max 375 W)
Accessories Include	Casters, RH Meter, 5 Shelves		

### Features

1. Can maintain an RH level of 1 % RH
2. Equipped with a digital RH Meter
3. Locking Doors
4. Shelves are adjustable and can hold 220 lbs (100 kgs.)
5. Grounded to prevent static electricity

# MCU Model 3%RH



## Features

1. Can maintain an RH level of 3%
2. Equipped with a digital RH Meter
3. Locking doors
4. Adjustable shelves
5. Loading capacity MCU-201, 301, 340, 580: 110lbs. (50kgs.)
6. Grounded to prevent static electricity

**Specifications:** (Note: Specifications are subject to change due to product improvement.)

Item/Model	MCU-201	MCU-301	MCU-401	MCU-340	MCU-580
External Dimensions (mm)	500 W x 570 D x 630 H	500 W x 630 D x 1200 H	500 W x 630 D x 1530 H	880 W x 500 D x 980 H	880 W x 800 D x 980 H
Internal Dimensions (mm)	480 W x 500 D x 540 H	480 W x 600 D x 1080 H	480 W x 600 D x 1410 H	830 W x 430 D x 790 H	830 W x 730 D x 790 H
Capacity	Approx 135 Liters	Approx 310 Liters	Approx 400 Liters	Approx 300 Liters	Approx 520 Liters
Dry Unit	US-3200	US-4000	US-4000	US-4000	US-5000
Material	Bonderized steel with melamine coating				
Color	Ivory				Silver
Door (Magnetic)	1 Door with glass window	2 Doors with glass windows	3 Doors with glass windows	2 Doors with glass windows	2 Doors with glass windows
Weight	Approx 30 kgs.	Approx 60 kgs.	Approx 70 kgs.	Approx 58 kgs.	Approx 80 kgs.
Electrical Requirement	230 V 21 W/h (Max 140 W)	230 V 33 W/h (Max 250 W)	230 V 33 W/h (Max 250 W)	230 V 33 W/h (Max 250 W)	230 V 47 W/h (Max 370 W)
Accessories Include	RH Meter, 4 shelves	RH Meter, 8 shelves		RH Meter, 3 shelves	

## Humidity Data of McDry Cabinets

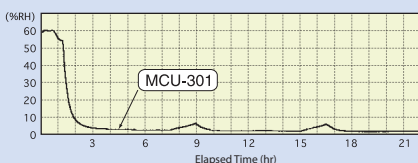

**MCU-301 (3% RH Model): Internal RH**

Test Conditions:  
27°C  
60% RH

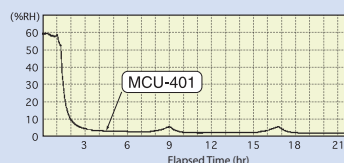

**MCU-401 (3% RH Model): Internal RH**

Test Conditions:  
28°C  
60% RH

# Feeder Bank 1%RH, 2%RH

CE



**DXU-580 SF**



**DXU-580 AF**



**DXU-1002-1000**



**DXU-4006**

## Specifications

Item/Model	DXU-580 SF	DXU-580 AF	DXU-1002-1000	DXU-4006
External Dimensions (mm)	880 W x 1200 D x 1324 H	880 W x 1200 D x 1600 H	1200 W x 1045 D x 1850 H	1650 W x 1305 D x 2255 H
Internal Dimensions (mm)	830 W x 1100 D x 790 H	830 W x 1100 D x 955 H	1150 W x 1000 D x 1552 H	1490 W x 1210 D x 2150 H
Capacity	Approx 900 Liters	Approx 900 Liters	Approx 2200 Liters	Approx 3800 Liters
Dry Unit	US-5000 x 2		US-6000 x 2	US-5000 x 8
Color	Ivory		Silver	Ivory
Door (Magnetic)	2 Doors with glass windows			
Weight	Approx 200 kgs.	Approx 240 kgs.	Approx 350 kgs.	Approx 1000 kgs.
Electrical Requirement	230 V 94 W/h (Max 740 W)		230 V 96 W/h (Max 500 W)	230 V Max 530 W
Accessories Include	Casters, RH Meter, 1 shelves		Casters, RH Meter, 5 shelves	Casters, RH Meter, 1 slide shelves

## MC Model 3%RH



1200 L  
MC-1001



1200 L  
MC-1002

### Features

1. Can maintain an RH level of 3%
2. Equipped with a digital RH Meter
3. Locking Doors
4. Shelves are adjustable and can hold 220lbs. (100kgs.)
5. Grounded to prevent static electricity



### Specifications

Item/Model	MC-1001	MC-1002
External Dimensions (mm)	1200 W x 700 D x 1850 H	
Internal Dimensions (mm)	1150 W x 600 D x 1610 H	
Capacity	Approx 1200 Liters	
Dry Unit	US-5000 x 1	
Color	Silver	
Door (Magnetic)	6 Doors with glass windows	4 Doors with glass windows
Weight	Approx 190 kgs.	Approx 180 kgs.
Electrical Requirement	230 V 47 W/h (Max 370 W)	
Accessories Include	Casters, RH Meter 5 shelves	

## Option

### Humidity instrumentation with alarm

Caution advisory indicator lights in case of exceeding the limited time and the set value.

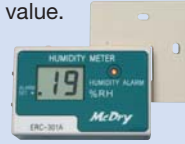

### Casters

It is possible to be installed for MCU type (DXU type is standard equipment.)



### Reel rack

Various tapes can be efficiently kept.

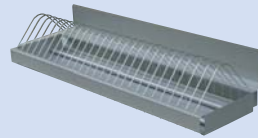

### Slide shelves

It is easy to take out the commodity by sliding the shelves



### Data logger

Record of humidity data



### Shelf board

The number of shelves can be increased. Stainless shelves are also available



### N2 socket

Using nitrogen is possible.



### Adjuster

Tip resistant



Agent Europe:

**SEIKA SANGYO GMBH**

Heltorferstr. 16 · D-40472 Düsseldorf  
 Telefon: +49 211 41580 · Telefax: +49 211 4791428  
 E-mail: INFO@seika-germany.com  
 Website: [www.seika-germany.com](http://www.seika-germany.com)

**ERC Co., Ltd.**

Ohya building Room 402, 3-16-11 Sagami-Ohno,  
 Sagami-hara City, Kanagawa, 228-0803, Japan  
 TEL +81 42-749-9751, FAX +81 42-744-2521  
[www.mcdry.co.jp](http://www.mcdry.co.jp)